

ARTÍCULO / ARTICLE:

Válvula de bola de una pieza roscada / *One piece threaded ball valve*

Características principales / *Main features:*

- **Paso reducido** / *Reduced port.*
- **Extremos roscados** / *Threaded ports: EN 10226-1 (ISO 7/1).*
- **Presión máxima** / *Maximum pressure: 69 bar.*
- **Maneta con bloqueo de seguridad** / *Handle with safety lock device.*

Características			
Nº	Cant.	Descripción	Material
1	1	Cuerpo	Microfusión AISI-316
2	1	Anillo de apriete	Microfusión AISI-316
3	1	Bola	Microfusión AISI-316
4	1	Asiento bola	PTFE +15% GF
5	1	Junta	PTFE
6	1	Eje	AISI-316
7	1	Arandela	PTFE
8	1	Prensaestopas	PTFE
9	1	Arandela	AISI-304
10	1	Maneta	AISI-304
11	1	Arandela Grower	AISI-304
12	1	Tuerca eje	AISI-304
13	1	Cubierta maneta	Plástico

Features			
N.	Qty.	Description	Material
1	1	Body	AISI-316 casting
2	1	Seal pressing ring	AISI-316 casting
3	1	Ball	AISI-316 casting
4	1	Ball seat	PTFE +15% GF
5	1	Seal	PTFE
6	1	Stem	AISI-316
7	1	Washer	PTFE
8	1	Stem packing	PTFE
9	1	Washer	AISI-304
10	1	Handle	AISI-304
11	1	Grower washer	AISI-304
12	1	Stem nut	AISI-304
13	1	Plastic cover	Plastic

GF = Fibra de vidrio / *Glass fibre*

Inoxpres, S.A.

Pol. Ind. Can Vinyals | C/ Elionor de Sicília, 11-13

08130 Sta. Perpètua de Mogoda (Bcn) | ESP

Tel. +34 935 754 136 | Fax +34 935 646 202

info@inoxpres.com

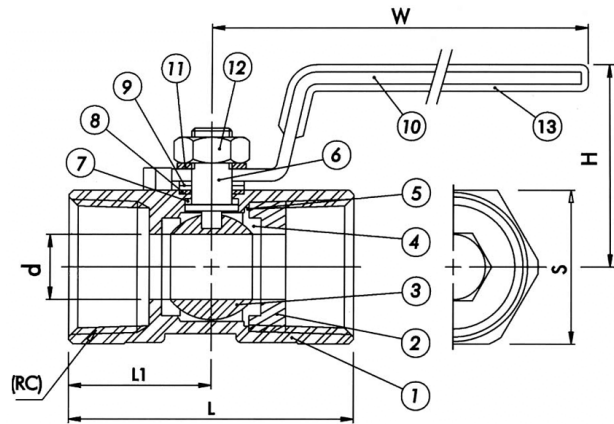

Código	DN	d (mm)	L (mm)	L1 (mm)	H (mm)	W (mm)	S (mm)	Peso (kg/ud)
61VIC008	1/4"	5,0	39	19,0	35	66	17	0,070
61VIC010	3/8"	7,0	44	21,0	36	74	21	0,102
61VIC015	1/2"	9,2	57	27,5	41	89	25	0,166
61VIC020	3/4"	12,5	59	30,0	44	89	32	0,247
61VIC025	1"	16,0	71	36,0	51	105	38	0,412
61VIC032	1.1/4"	20,0	78	39,0	56	105	48	0,672



Gráfico 1. Relación temperatura de operación y presión máxima / Working temperature and maximum pressure relation.



Nota / Note:

Los valores mostrados en esta ficha son datos aproximados y meramente orientativos, que pueden verse alterados por factores como el tipo de fluido, la densidad, la viscosidad y la rugosidad de la superficie del material. INOXPRES, S.A no se responsabiliza de los cálculos realizados por terceros, las ingenierías y los instaladores deben realizar sus propios cálculos y comprobaciones de las instalaciones proyectadas

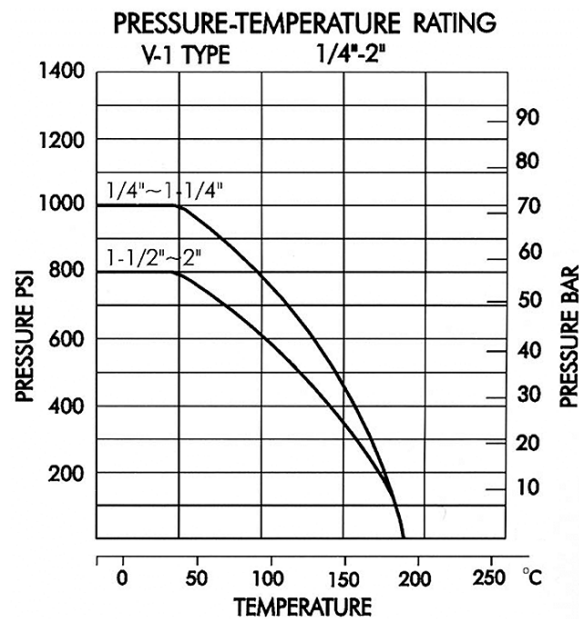
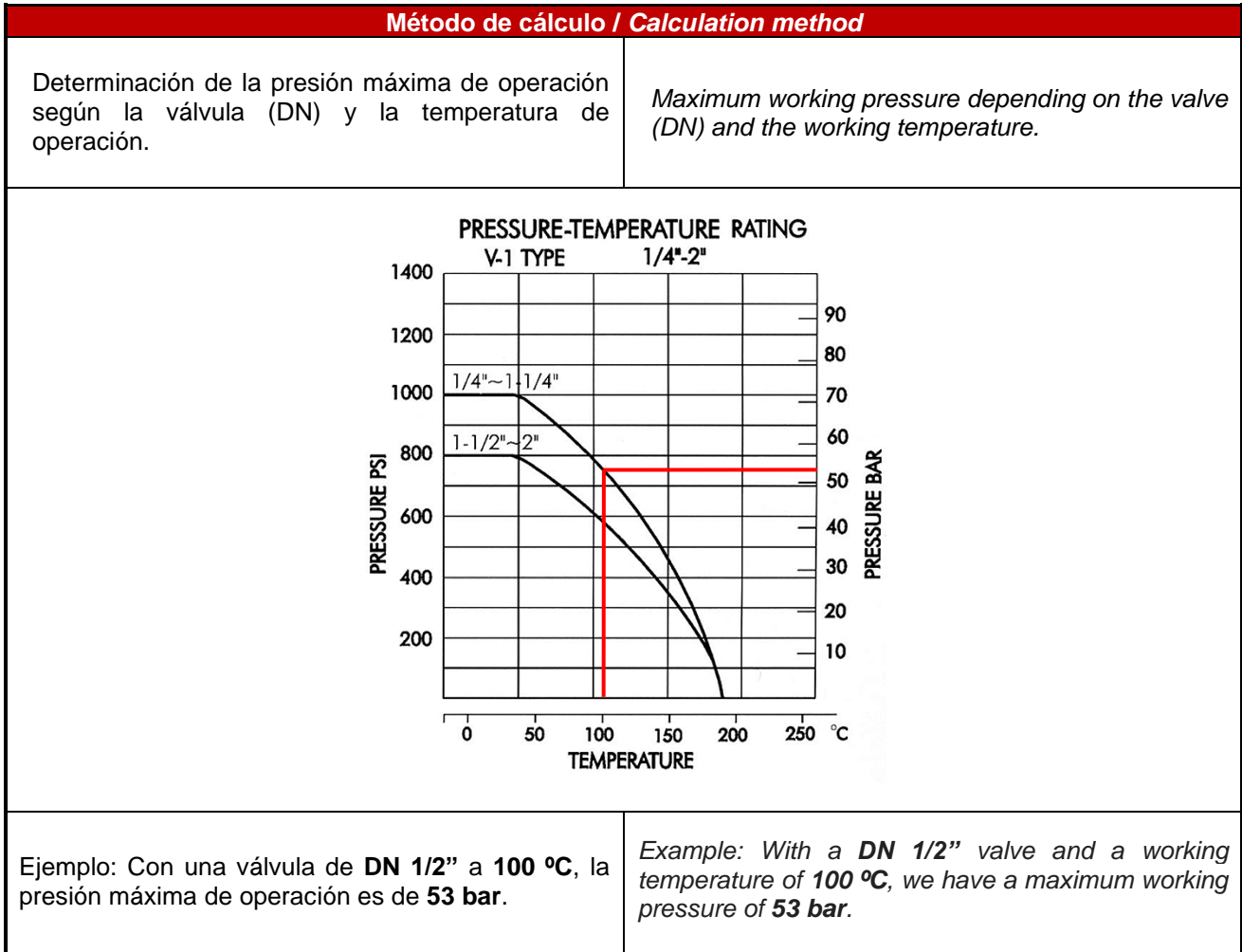
La relación comercial entre INOXPRES, S.A y sus clientes, estará sujeta a las condiciones generales de venta publicada en el enlace www.inoxpres.com/condiciones-generales-de-venta/

The values shown in this sheet are approximate and merely indicative data, which can be altered by factors such as the type of fluid, the density, the viscosity and the roughness of the material's surface. INOXPRES, S.A is not responsible for the calculations made by third parties, engineering companies and installers must carry out their own calculations and checks of the planned installations.

The commercial relationship between INOXPRES, S.A and its clients will be subject to the general conditions of sale published in the link www.inoxpres.com/condiciones-generales-de-venta/

Inoxpres, S.A.

Pol. Ind. Can Vinyals | C/ Elionor de Sicília, 11-13

08130 Sta. Perpètua de Mogoda (Bcn) | ESP

Tel. +34 935 754 136 | Fax +34 935 646 202

info@inoxpres.com